

NOTE: BREAK ALL CORNERS WITH 0.015" (.38 MM) RADIUS UNLESS OTHERWISE NOTED. STANDARD TOLERANCES TO APPLY UNLESS OTHERWISE SPECIFIED.

CUSTOMER CAN ART OPEN	DIE No. ES16746	REV. No. 0
DESCRIPTION EXTERIOR SILL	CUSTOMER PART No.	QUOTE No. 10-0486-8
		PROPOSAL No. S-26115

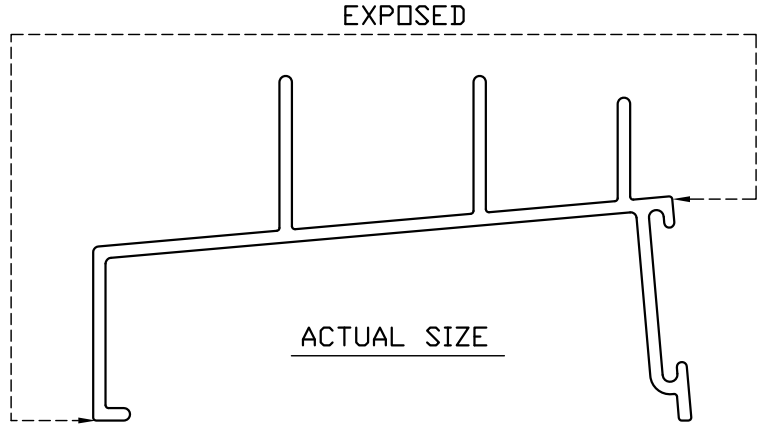
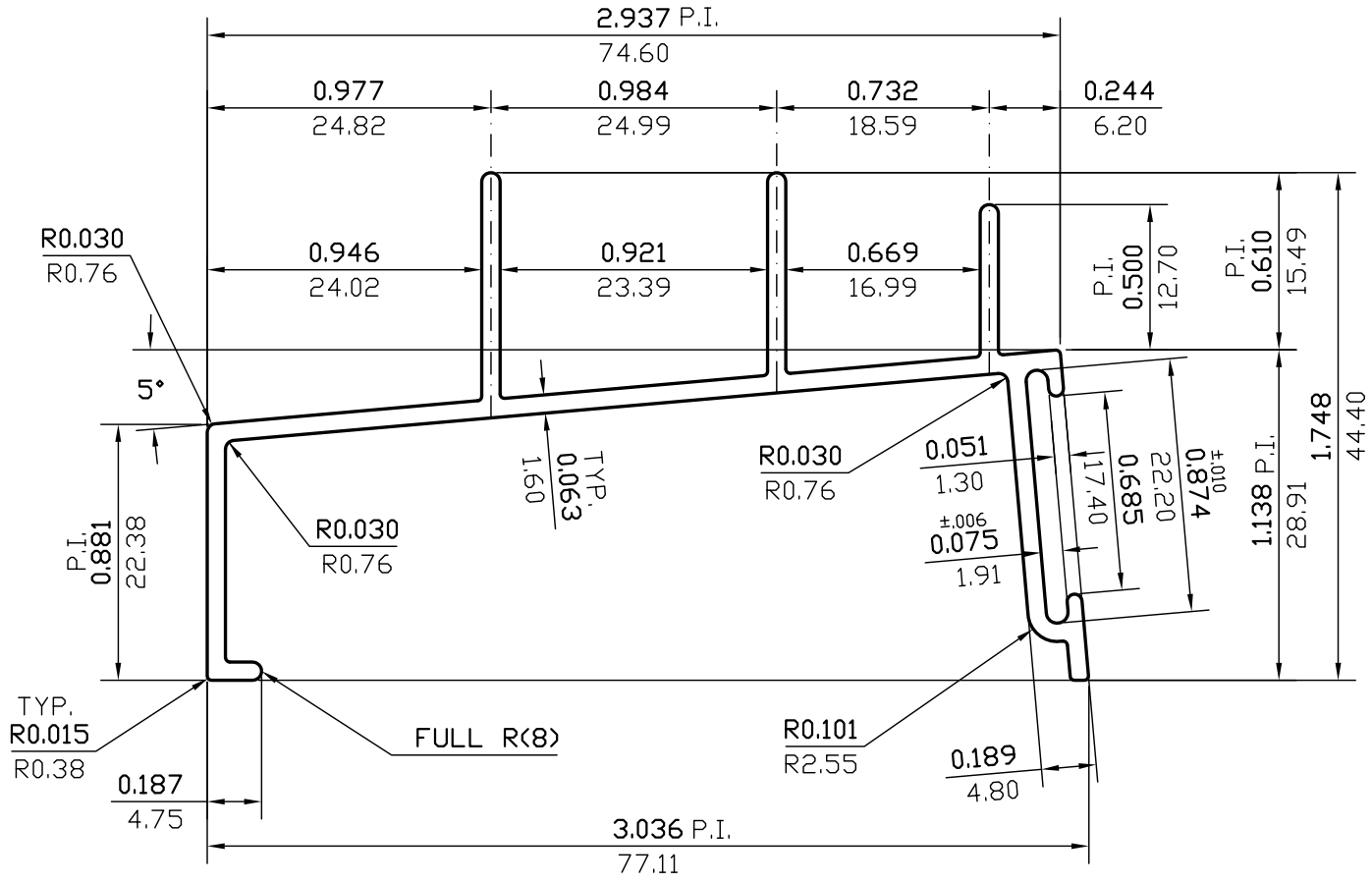

WALL THICKNESS **0.063(1.60)** EXCEPT AS SHOWN

DATE	REV	DESCRIPTION	BY
EST.AREA	0.454	IN. ²	EST.AREA 292.821 MM. ²
EST.WT.	0.536	LBS./FT.	EST.WT. 0.797 KG/M.
EST.PER.	14.325	IN.	EST.PER. 363.844 MM.
OUT PER.		IN.	OUT PER. MM.
C.C.D.	3.220	IN.	C.C.D. 81.780 MM.
FINISH	PAINT	ALLOY	6063
CKD BY	FACTOR 27	SCALE 1.5:1	DWN BY C.P. DATE 04/17/2012

CAN ART

85 PARKSHORE DRIVE
BRAMPTON, ONT L6T 5M1
TEL. NO. (905) 791-1464
FAX NO. (905) 791-9151
WEB: www.canart.com

ALUMINUM EXTRUSION INC.

THIS DRAWING IS NOT NECESSARILY A COPY OF YOUR ORIGINAL. PLEASE APPROVE DIMENSIONS AND TOLERANCES INDICATED. CAN ART ASSUMES NO RESPONSIBILITY EITHER TECHNICAL OR LEGAL FOR HAVING THIS SHAPE MADE. THE CUSTOMER AGREES TO FULLY PROTECT CAN ART ALUMINUM FROM CLAIMS OF OTHERS RESULTING FROM THIS SHAPE.

SIGNED: _____ DATE: _____