

NOTE: BREAK ALL CORNERS WITH 0.015" (.38 MM) RADIUS UNLESS OTHERWISE NOTED. STANDARD TOLERANCES TO APPLY UNLESS OTHERWISE SPECIFIED.

CUSTOMER <h1 style="text-align: center; margin: 0;">CAN ART OPEN</h1>	DIE No. <h2 style="text-align: center; margin: 0;">EH20574</h2>	REV. No. <h1 style="text-align: center; margin: 0;">0</h1>
DESCRIPTION	CUSTOMER PART No.	QUOTE No. <b>20-0884-2</b>
		PROPOSAL No. <b>H-40601</b>

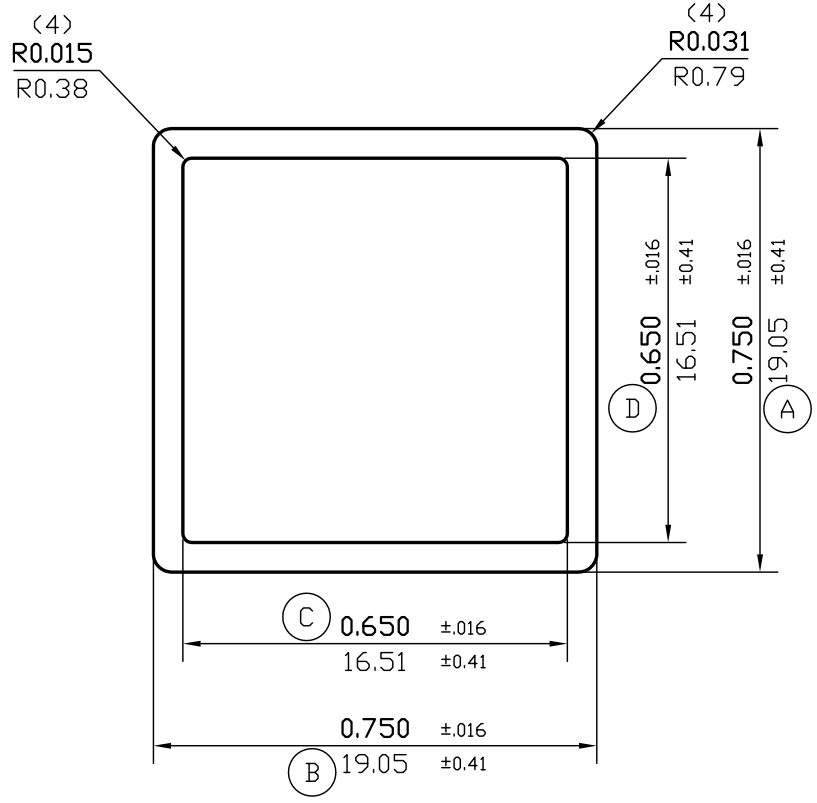

EXPOSED ALL AROUND

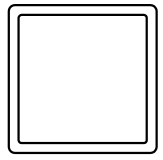

ACTUAL SIZE

WALL THICKNESS  $\begin{matrix} \textcircled{E} & +.010 & +.025 \\ & -.006 & -.015 \end{matrix}$  **0.050 (1.27)** EXCEPT AS SHOWN

DATE	REV	DESCRIPTION	BY
EST.AREA	<b>0.139</b>	IN. <sup>2</sup>	EST.AREA <b>89.911</b> MM. <sup>2</sup>
EST.WT.	<b>0.164</b>	LBS./FT.	EST.WT. <b>0.245</b> KG/M.
EST.PER.	<b>5.521</b>	IN.	EST.PER. <b>140.231</b> MM.
OUT PER.	<b>2.947</b>	IN.	OUT PER. <b>74.8</b> MM.
C.C.D.	<b>1.035</b>	IN.	C.C.D. <b>26.286</b> MM.
FINISH	<b>M/F</b>		ALLOY <b>6063</b>
CKD BY	FACTOR <b>34</b>	SCALE <b>3:1</b>	DWN BY <b>G.W.</b> DATE <b>08/06/2020</b>

# CAN ART

428 JUTRAS DRIVE S.  
WINDSOR, ON N8N 5C5  
TEL. NO. (519) 727-4399  
FAX NO. (519) 727-6434  
WEB: www.canart.com

ALUMINUM EXTRUSION L.P.

THIS DRAWING IS NOT NECESSARILY A COPY OF YOUR ORIGINAL. PLEASE APPROVE DIMENSIONS AND TOLERANCES INDICATED. CAN ART ASSUMES NO RESPONSIBILITY EITHER TECHNICAL OR LEGAL FOR HAVING THIS SHAPE MADE. THE CUSTOMER AGREES TO FULLY PROTECT CAN ART ALUMINUM FROM CLAIMS OF OTHERS RESULTING FROM THIS SHAPE.

SIGNED: \_\_\_\_\_ DATE: \_\_\_\_\_