

CUSTOMER PART No.

CUSTOMER

# CAN ART OPEN

DIE No.

EH10802

DESCRIPTION

SQUARE TUBE

PROPOSAL No.

H-9323

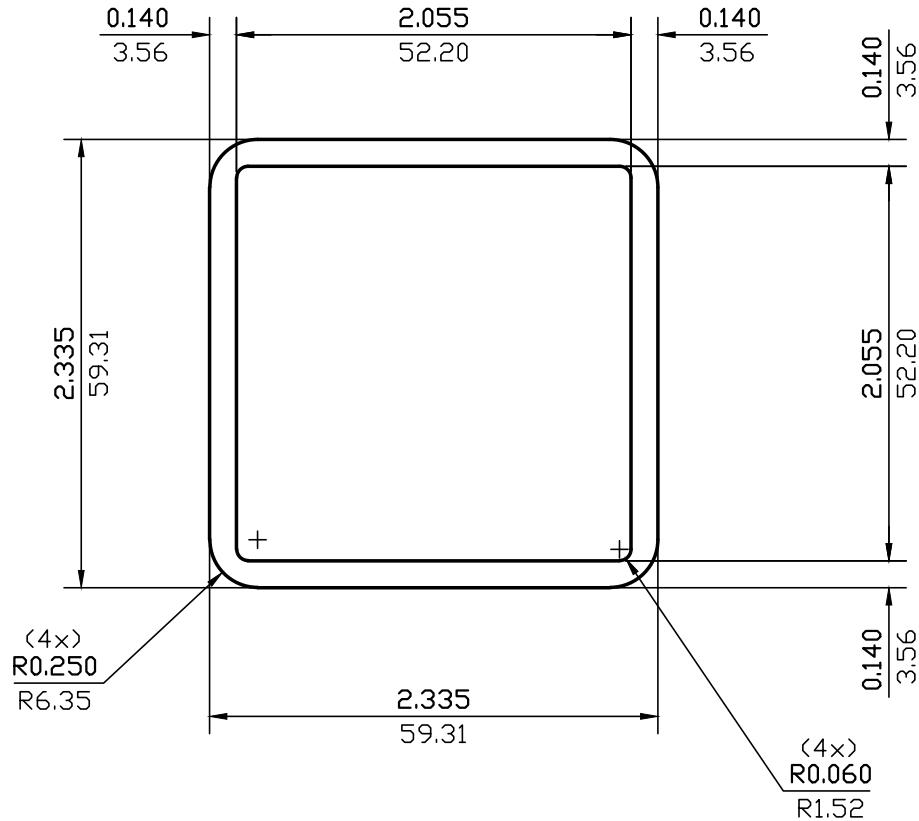

NOTE: BREAK ALL CORNERS WITH 0.015" (.38 MM) RADIUS UNLESS OTHERWISE NOTED. STANDARD TOLERANCES TO APPLY UNLESS OTHERWISE SPECIFIED.

WALL THICKNESS 0.140(3.56) EXCEPT AS SHOWN

DATE	REV	DESCRIPTION	BY
EST.AREA	1.179	IN. <sup>2</sup>	EST.AREA 760
EST.WT.	1.414	LBS/FT.	EST.WT. 2.105
EST.PER.	17.028	IN.	EST.PER. 432.5
OUT PER.	8.911	IN.	OUT PER. 226.3
C.C.D.	3.095	IN.	C.C.D. 79
FACTOR	12	FINISH M/F	ALLOY & TEMP. 6063-T6
CKD BY	SCALE 1:1	DWN BY C.P.	DATE 11/11/99

## CAN ART

ALUMINUM EXTRUSION INC.

85 PARKSHORE DRIVE  
BRAMPTON, ONT L6T 5M1  
TEL. NO. (905) 791-1464  
FAX NO. (905) 791-9151  
E-MAIL: canart@canart.com

THIS DRAWING IS NOT NECESSARILY A COPY OF YOUR ORIGINAL. PLEASE APPROVE DIMENSIONS AND TOLERANCES INDICATED. CAN ART ASSUMES NO RESPONSIBILITY EITHER TECHNICAL OR LEGAL FOR HAVING THIS SHAPE MADE. THE CUSTOMER AGREES TO FULLY PROTECT CAN ART ALUMINUM FROM CLAIMS OF OTHERS RESULTING FROM THIS SHAPE.

SIGNED: \_\_\_\_\_ DATE: \_\_\_\_\_