

CUSTOMER PART No.

CUSTOMER

CAN ART OPEN

DIE No.

ES05106

DESCRIPTION

PROPOSAL No.

S-373

NOTE: BREAK ALL CORNERS WITH 0.015" (.38 MM) RADIUS UNLESS OTHERWISE NOTED. STANDARD TOLERANCES TO APPLY UNLESS OTHERWISE SPECIFIED.

EXPOSED SURFACE

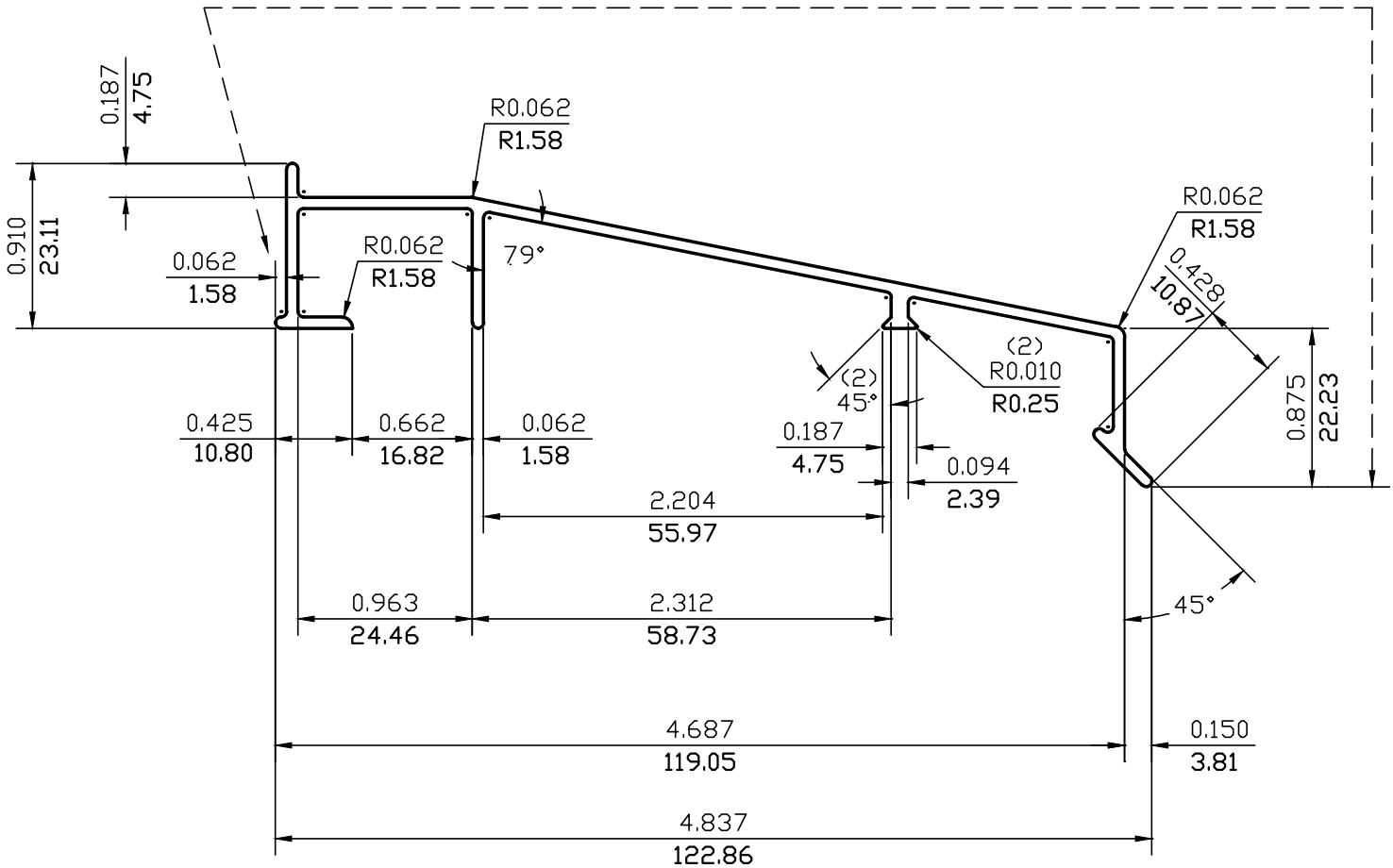

NOTE:
 (< . >) = R0.031 (< R0.79 >) (< 10 >)
 UNMARKED RAD = FULL

WALL THICKNESS 0.062 (1.57) EXCEPT AS SHOWN

DATE	REV	DESCRIPTION	BY
EST.AREA	0.491	IN. ²	EST.AREA 316.636
EST.WT.	0.579	LBS./FT.	EST.WT. 0.862
EST.PER.	15.377	IN.	EST.PER. 390.577
OUT PER.		IN.	OUT PER.
C.C.D.	5.076	IN.	C.C.D. 128.940
FACTOR 27	FINISH	ALLOY & TEMP. 6063-T5	
CKD BY	SCALE 1:1	DWN BY G.M.	DATE 02/09/88

CAN ART

ALUMINUM EXTRUSION INC.

85 PARKSHORE DRIVE
 BRAMPTON, ONT L6T 5M1
 TEL. NO. (905) 791-1464
 FAX NO. (905) 791-9151
 E-MAIL: canart@canart.com

THIS DRAWING IS NOT NECESSARILY A COPY OF YOUR ORIGINAL. PLEASE APPROVE DIMENSIONS AND TOLERANCES INDICATED. CAN ART ASSUMES NO RESPONSIBILITY EITHER TECHNICAL OR LEGAL FOR HAVING THIS SHAPE MADE. THE CUSTOMER AGREES TO FULLY PROTECT CAN ART ALUMINUM FROM CLAIMS OF OTHERS RESULTING FROM THIS SHAPE.

SIGNED: _____ DATE: _____